



EUROLASTIC TC 30 G black

approved 2-component polysulphide sealant, pourable



-  Joint sealant: EUROLASTIC TC 30 G
-  Primer: EUROLASTIC Primer U 12 G or EUROLASTIC Primer S2
-  Backing material: round PE cord (closed-cell)

Product description

EUROLASTIC TC 30 G is a pourable, highly chemical-resistant, resilient, polysulphide-based 2-component joint sealant suitable for processing with 2-component equipment.

Area of application

- for indoor and outdoor use
- for storage, filling and handling facilities for water-polluting substances, filling stations, air and road traffic areas, production and storage areas

Product characteristics

- cold elasticity to -40°C
- highly resistant to chemicals, e.g. fuels, oils, aircraft fuels, de-icing agents and numerous other media in accordance with the chemical resistance list
- very high UV, weathering and ageing resistance
- excellent resistance to notching and wear
- approved total deformation 25% , recovery capability > 90%

Colour

Black

Substrate preparation

The substrate temperature must be between $+5^{\circ}\text{C}$ and $+35^{\circ}\text{C}$, and the temperature of the bonding surfaces must be at least



3°C above the prevailing dew point temperature. At the time of jointing, the bonding surfaces must be clean, free of oil and grease, dry and free of substances that could prevent adhesion.

Backing

The joint space must be tightly and firmly backed with closed-cell polyethylene backer rod. The rod must not be damaged during application.

Primer

Basically, EUROLASTIC TC 30 G may only be applied to primed bonding surfaces.

Absorbent substrates:

EUROLASTIC Primer U12G

Non-absorbent substrates:

EUROLASTIC Primer S2

Bare steel and galvanised surfaces:

EUROLASTIC Primer ZM after curing EUROLASTIC Primer S2 must be applied.

See primer matrix for further information

Processing conditions

Material temperature for manual processing:

min. +10°C, max. +25°C

Material temperature for mechanical processing:

min. +10°C, max. +60°C

Ambient temperature between +5°C and +40°C

Processing

EUROLASTIC TC 30 G is supplied with the correct ratio of components A and B. Add all of component B to component A and mix thoroughly with a slow agitator at approx. **300 rpm**.

The mixing process must be carried out until a homogeneous, streak-free mixture forms. Do not mix for less than 3-5 minutes.

Place the mixture in a caulking gun or insert the container into a pressure tank with a hose and nozzle. The joint chamfer must not serve as a bonding surface when sealing the joint. Air bubbles that form on the surface during installation can be removed during the sealant processing time by gentle brushing with a dry, soft brush.

The joint sealant installation must be carried out in accordance with CUAP (Common Understanding of Assessment Procedure) "Joint Sealant Systems" – see DIBt



European technical approval.

trafficable joint assembly

non-trafficable joint assembly

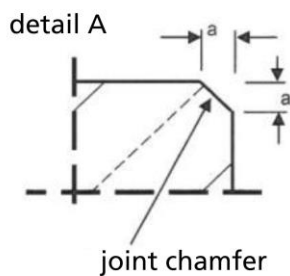
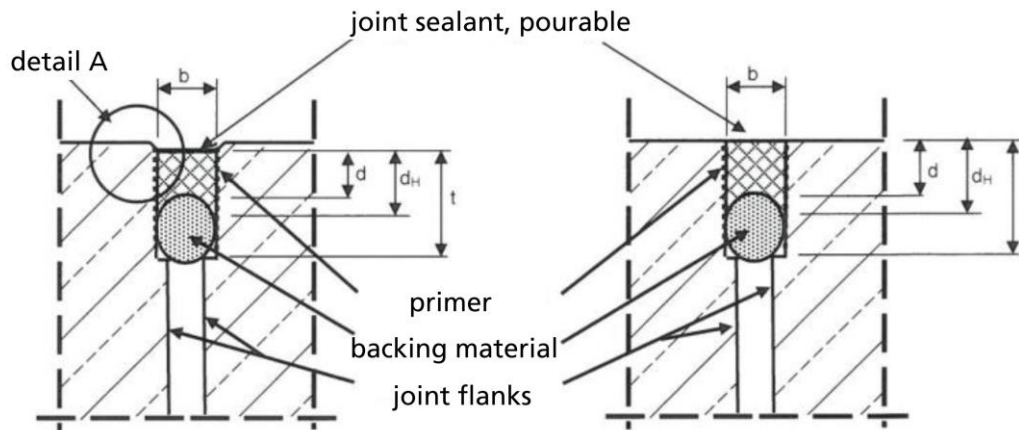

- a = chamfer face (3 to 10 mm)
- b = joint width (10 to 20 mm trafficable, non-trafficable up to 40 mm)
- d = joint sealant thickness
- dH = joint sealant adhesion or contact surface on the joint flank; $dH = d + 0.5 b$
- t = depth of joint slot

Joint Design Dimensions

Trafficable with pneumatic tyre vehicles			
	b	d	d _H
min.	10	10	15
max.	20	20	30

Non-trafficable			
	b	d	d _H
min.	10	10	15
max.	40	40	60

Cleaning

Fresh material can be removed from the tools with EUROLASTIC Cleaner G. Fully cured material requires mechanical cleaning.



Consumption

Joint width in mm	Joint depth in mm	Consumption in ml/m
10	10	approx. 100
15	12 - 15	approx. 180 - 225
20	16 - 20	approx. 320 - 400
25	20 - 25	approx. 500 - 625
30	24 - 30	approx. 720 - 900
35	28 - 35	approx. 980 - 1,225
40	32 - 40	approx. 1,280 - 1,600

Packaging

EUROLASTIC TC 30 G is delivered in 4 l, 10 l, 20 l and 200 l containers.

Storage and shelf life

Store in a cool, dry place (+10°C to +25 °C). Under these conditions, the shelf life of unopened and undamaged original containers is 12 months.

Tests/ Approvals/Standards

EUROLASTIC TC 30 G complies with the European technical approval granted by DIBt (German Institute of Building Technology):

- Z-74.6-133
- And the tests of:
- TL-Fug StB 01/ ZTV-Fug StB 01
- DIN EN 14188-2

Special instructions/protective measures

EUROLASTIC TC 30 G may only be processed in well-ventilated areas. Suitable protective clothing must be worn when working. Waste and containers must be disposed of in a safe manner. Avoid release into the environment. Completely empty containers can be returned to the KBS/Interseroh circulatory system.

The instructions in the corresponding safety data sheet must be strictly adhered to.



Technical data*		
Technical properties	Unit	Value
Material basis		Polysulphide/manganese dioxide
Mixture ratio A:B	Parts by	100:20
Number of components		2-component
Density at +23°C	g/cm ³	1.50 - 1.55
Solid volume at +23°C	%	100
Viscosity at +23°C		Pourable
Processing time at +23°C/50% relative humidity	hrs	1 - 2
Curing time at +23°C/50% relative humidity	hrs	24 - 48*
Object and processing temperature	°C	from +5 to +35
Temperature resistance	°C	from -40 to +120
Mechanical properties	Unit	Value
Shore hardness		approx. 20
Approved total deformation	%	25
Tensile stress at +23°C	N/mm ²	approx. 0.20
Tensile stress at -20°C	N/mm ²	approx. 0.34
Recovery capability	%	> 90
Chemical resistance	see chemical resistance list or technical approval	

* These are approximate values. The values are not intended for the preparation of specifications.

When processing the sealant with a heated 2-component mixing and dosing system (max. + 60 °C), divide the curing times by two.

The data was calculated at +23°C and 50% relative humidity. Higher temperatures and/or higher relative humidity may shorten or extend these times. All technical data, measurements and information in this data sheet are based on laboratory tests. Actual measured data may deviate in practice.

February 2017/We reserve the right to make technical changes and refinements. No liability assumed for advertising documents. Consultation of any kind, also due to any industrial property rights of third parties, shall be considered non-binding. The customer is solely responsible for the suitability of the goods for the particular intended use. All orders are subject to the seller's/manufacturer's terms and conditions for the sale and/or manufacture of the goods. Reproduction not permitted.